



BROTHERS
PHARMAMACH (INDIA) PVT. LTD.

LABELSTIK 120c.Twin

Automatic Twin Head

Carton Security Label Sticker Labelling Machine

The Automatic Sticker Labelling Machine Model LABELSTIK-120C-Twin, is one of the most user friendly. The Machine incorporates latest sophisticated Micro Processor Control Label Dispensing system with user friendly Sensing system for Label and Product. The machine is suitable for applying **Two Side Security Labels** in "L" Shape on Two side of Cartons with speed upto 120 Products per minute depending on cartons and label size. Machine can be used for Self Adhesive Paper Labels, Film Labels or Hologram. It is capable of Labelling up to 120 units per minute depending on Product Size, Shape, Product movement direction and Label size. Machine suitable for all type Cartons.

Machine can be used for Offline or Online application, however customer require to send us sample of cartons and also detail of carton position while movement as the position of carton is important and required to feed and desired position for two side label application. LABELSTIK-120C.Twin Machine having required all basic features as a standard fitment to match the current market needs and also saves cost and time. Machine also available with optional special features of applying Twin Label on products from Single Label Roll or application of Label on product at regular intervals.

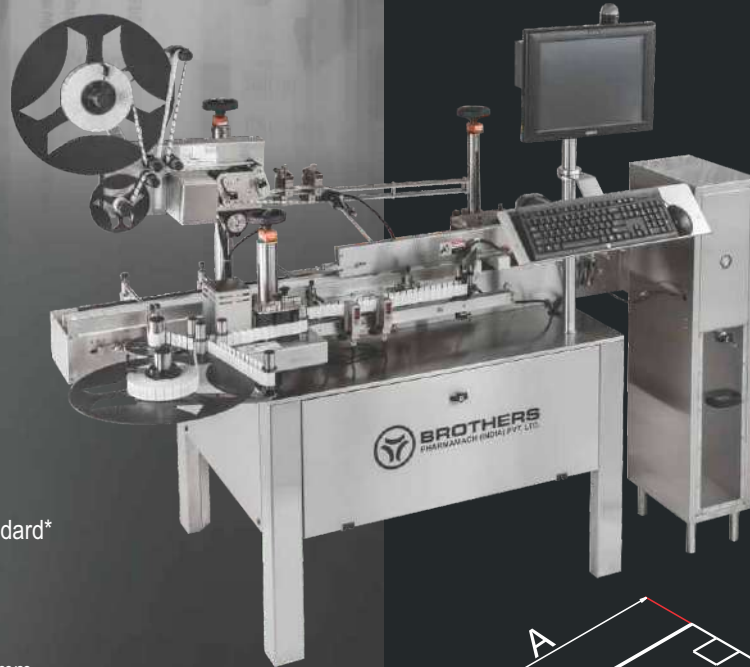

TECHNICAL SPECIFICATIONS

- Label Height : 8 mm to 70 mm Standard*
- Label Length : 12 mm Minimum
- Label Roll Dia. : 400 mm
- Core Dia. : 75/76 mm
- Gap Between two Labels : appx. 3 mm
- Product Feeding : Cartons required to feed on machine with regular interval/gap between cartons in required position by customer or required to feed manually by operator on machine in required position.
- Electrical : 220 VAC Single Phase Power Supply (50/60 Hz)
- Power : 1.0 Hp, 1.5 Amp.
- Capacity : 0.75 Kw
- Speed : LABELSTIK-120C.Twin up to 120 Labels per minute
LABELSTIK-250C.Twin up to 240 Labels per minute.
Speed of Machine depending on Label Size and Carton Size.
- Conveyor height : 830-875 mm*
- Overall dimension : 2440 mm(L) X 1300 mm(W) X 1600 mm (H) with T.G. Cabinet 2440 mm(L) X 1300 mm(W) X 1600 mm (H)
- Machine Direction of Movement : Left to Right from operator side

* Specification can be changed as per customers requirements

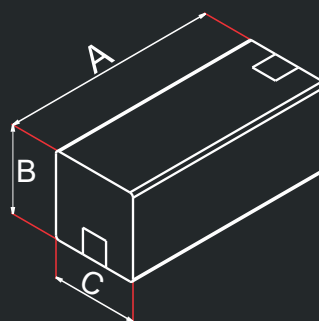

Machine Type : A (Small Size)			
Size	A	B	C
Min.	55 mm	30 mm	30 mm
Max.	115 mm	125 mm	125 mm

Machine Type : B (Standard Size)			
Size	A	B	C
Min.	70 mm	30 mm	30 mm
Max.	175 mm	125 mm	125 mm

Machine Type : B (Standard Size)			
Size	A	B	C
Min.	150 mm	30 mm	30 mm
Max.	250 mm	200 mm	200 mm

Other Available Models

LABELSTIK-250F.Twin	LABELSTIK-600	LABELSTIK-120H	LABELSTIK-150
LABELSTIK-250C.Twin	LABELSTIK-300HG	LABELSTIK-120R	LABELSTIK-150B
LABELSTIK-120R.Twin	LABELSTIK-300LR	LABELSTIK-300	LABELSTIK-400
LABELSTIK-100F.Twin	LABELSTIK-EXCEL	LABELSTIK-120C	LABELTUBE-60

For Built-in / Optional* Items Refer UNIQUE FEATURES Page for more details.

Email : sales@brothers.in
Export : sales1@brothers.in

Phone : +91 79 40213213 / 25831346

www.brothersindia.com